

# ***RALLYE BRESLAU*** ***INTERNATIONAL ASSN.***



# APPENDIX 4

# ROLL CAGE

# FIA GUIDELINES

Changes = thus

Version released on 13.02.2017

## 1. GENERAL

**1.1. The following material is a quote from the FIA Appendix J Article 283 – Safety equipment for Cross-country vehicles. For Trucks please refer to FIA Appendix J Article 287 - Cross-Country Truck Technical Regulations. The texts have guidance purposes only.**

**1.2. The roll cage does not require any homologation/ technical passport.**

**1.3. Acceptable roll cage for the cars will be the one which have “the basic structure” stated in p.3.1 plus “diagonal members” stated in p.3.3.1. The chief scrutener will inspect each roll cage for compliance considering the vehicle weight, class and category.**

**1.4. External roll cages are allowed for extreme class and Cross-country Trucks category**

1.5. The complete information regarding the FIA Appendix J can be found on the following link:  
<http://www.fia.com/regulation/category/100>

## 2. DEFINITIONS

### 2.1. Safety cage

Multi-tubular structure installed in the cockpit and fitted close to the bodyshell, the function of which is to reduce the deformation of the bodyshell (chassis) in case of an impact.

### 2.2. Rollbar

Tubular frame forming a hoop with two mounting feet.

### 2.3. Main rollbar (Drawing 253-1)

Transverse and near-vertical (maximum angle +/-10° to the vertical) single piece tubular hoop located across the vehicle just behind the front seats. The tube axis must be within one single plane.

### 2.4. Front rollbar (Drawing 253-1)

Similar to main rollbar but its shape follows the windscreen pillars and top screen edge.

### 2.5. Lateral rollbar (Drawing 253-2)

Near-longitudinal and near-vertical single piece tubular hoop located along the right or left side of the vehicle, the front pillar of which follows the windscreen pillar and the rear pillar of which is near-vertical and located just behind the front seats. The rear pillar must be straight in side view.

### 2.6. Lateral half-rollbar (Drawing 253-3)

Identical to the lateral rollbar but without the rear pillar.

### 2.7. Longitudinal member

Near-longitudinal single piece tube joining the upper parts of the front and main rollbars.

### 2.8. Transverse member

Near-transverse single piece tube joining the upper parts of the lateral half-rollbars or of the lateral rollbars.

### 2.9. Diagonal member

Transverse tube between : One of the top corners of the main rollbar, or one of the ends of the transverse member in the case of a lateral rollbar, and at the lower mounting point on the opposite side of the rollbar.

or

The upper end of a backstay and the lower mounting point of the other backstay.

2.10. Removable members

Members of a safety cage which must be able to be removed.

2.11. Cage reinforcement

Member added to the safety cage to improve its strength.

2.12. Mounting foot

Plate welded to the end of a rollbar tube to permit its bolting to the bodyshell/chassis, usually onto a reinforcement plate. This plate may be welded to the bodyshell/chassis in addition to the bolts.

2.13. Reinforcement plate

Metal plate fixed to the bodyshell/chassis under a rollbar mounting foot to better spread the load onto the bodyshell/chassis.

2.14. Gusset

Reinforcement for a bend or junction made from bent sheet metal with a U shape the thickness of which must not be less than 1.0 mm.

The ends of this gusset (point E) must be situated at a distance from the top of the angle (point S) of between 2 to 4 times the outer diameter of the biggest of the tubes joined.

A cut-out is permitted at the top of the angle but its radius (R) must be no greater than 1.5 times the outer diameter of the biggest of the tubes joined.

The flat sides of the gusset may have a hole the diameter of which must not be greater than the outer diameter of the biggest of the tubes joined.

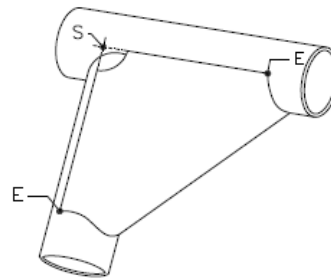

### 3. SPECIFICATION

3.1. Basic structure

The basic structure must be made according to one of the following designs:

- 1 main rollbar + 1 front rollbar + 2 longitudinal members + 2 backstays + 6 mounting feet (Drawing 253-1)

or

- 2 lateral rollbars + 2 transverse members + 2 backstays + 6 mounting feet (Drawing 253-2)

or

- 1 main rollbar + 2 lateral half-rollbars + 1 transverse member + 2 backstays + 6 mounting feet (Drawing 253-3)

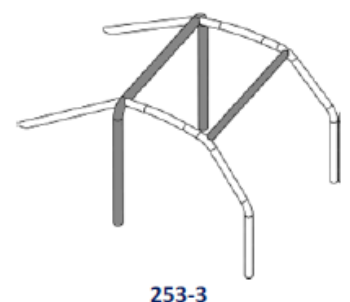
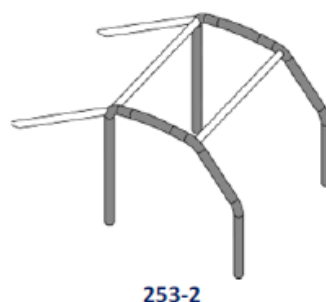

The vertical part of the main rollbar must be as close as possible to the interior contour of the bodyshell and must have only one bend with its lower vertical part. The front pillar of a front rollbar or of a lateral rollbar must follow the windscreen pillars as closely as possible and have only one bend with its lower vertical part.

### 3.2. Design

Once the basic structure is defined, it must be completed with compulsory members and reinforcements to which optional members and reinforcements may be added

### 3.3. Compulsory members and reinforcements

#### 3.3.1. Diagonal members

The cage must have one of the diagonal members defined by Drawings 253-4, 253-5, 253-6, 253-7.

The orientation of the diagonal may be reversed. In the case of Drawing 253-6, the distance between the two mountings on the bodyshell/chassis must not be greater than 300mm.

Members must be straight and may be removable.

The upper end of the diagonal must join the main rollbar no further than 100 mm from its junction with the backstay, or the backstay no more than 100 mm from its junction with the main rollbar.

The lower end of the diagonal must join the main rollbar or the backstay no further than 100 mm from the mounting foot (except for the case of Drawing 253-6).

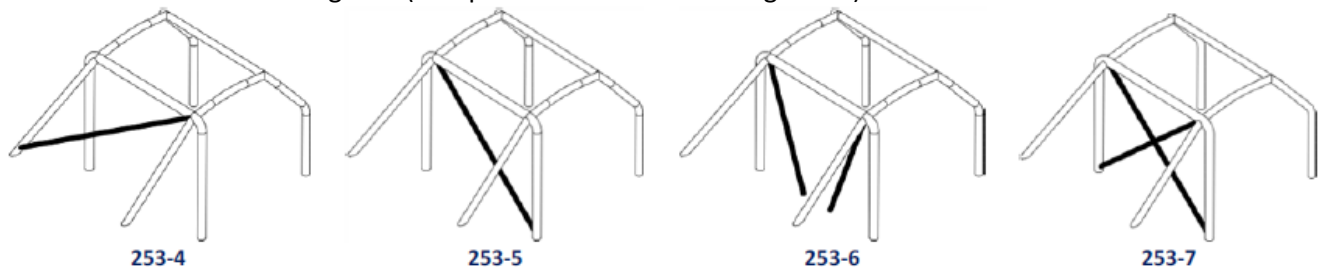

#### 3.3.2. Door members

One or more longitudinal members must be fitted at each side of the vehicle according to Drawings 253-8, 253-9, 253-10 and 253-11

Drawings may be combined. The design must be identical on both sides. They may be removable. The side protection must be as high as possible, but its upper attachment point must not be higher than half the height of the door opening measured from its base.

If these upper attachment points are located in front of or behind the door opening, this height limitation is also valid for the corresponding intersection of the strut and the door opening.

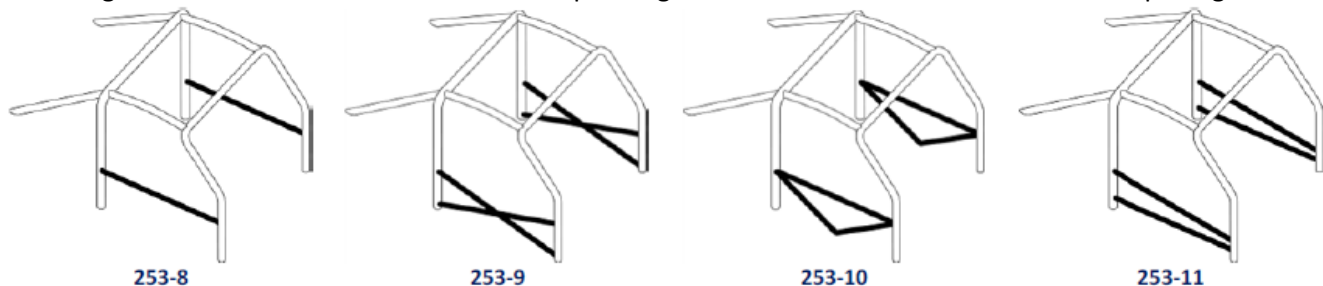

#### 3.3.3. Roof reinforcement

The upper part of the safety cage must comply with one of Drawings 253-12, 253-13 and 253-14. The reinforcements may follow the curve of the roof. For competitions without co-drivers, in the case of Drawing 253-12 only, only one diagonal member may be fitted but its front connection must be on the driver's side. The ends of the reinforcements must be less than 100 mm from the junction between rollbars and members (not applicable to the top of the V formed by reinforcements in Drawings 253-13 and 253-14).

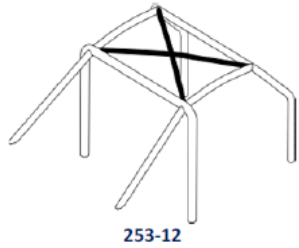

253-12

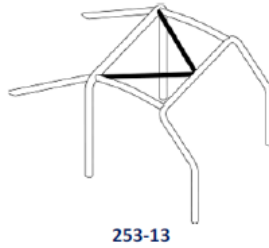

253-13

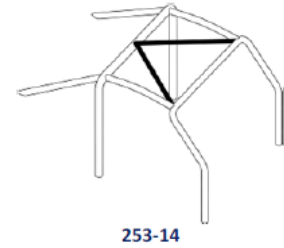

253-14

### 3.3.4. Additional reinforcement

See the FIA Appendix J for details.

### 3.3.5. Mounting of safety cages to the bodyshell/chassis

#### 3.3.5.1. Mounting points of the front, main, lateral rollbars or lateral halfrollbars

Each mounting point must include a reinforcement plate at least 3 mm thick.

Each mounting foot must be attached by at least three bolts on a steel reinforcement plate at least 3 mm thick and of at least 120 cm<sup>2</sup> area which is welded to the bodyshell.

Fixing bolts must have a minimum diameter of M8 and a minimum quality of 8.8 (ISO standard).

Fasteners must be self-locking or fitted with lock washers.

The angle between 2 bolts must not be less than 60 degrees.

#### 3.3.5.2. Mounting points of the backstays

Each backstay must be secured by a minimum of 2 M8 bolts with mounting feet of at least 60 cm<sup>2</sup> area, or secured by a single bolt in double shear, provided it is of adequate section and strength and provided that a bush is welded into the backstay.

### 3.4. Tube specification

Only tubes with a circular section are authorised.

Material	Minimum tensile strength	Minimum dimensions (mm)	Use
Cold drawn seamless Unalloyed carbon steel (see below) containing a maximum of 0.3 % of carbon	350 N/mm <sup>2</sup>	45 x 2.5 (1.75"x0.095") or 50 x 2.0 (2.0"x0.083")	Main rollbar (Drawings 253-1 and 253-3) or Lateral rollbars and Rear Transverse member (Drawing 253-2)
		38 x 2.5 (1.5"x0.095") or 40 x 2.0 (1.6"x0.083")	Lateral halfrollbars and other parts of the safety cage (unless otherwise indicated in the articles above)

For unalloyed steel, the maximum content of additives is 1.7 % for manganese and 0.6 % for other elements.

In selecting the steel, attention must be paid to obtaining good elongation properties and adequate weldability.

The tubing must be bent by a cold working process and the centreline bend radius must be at least 3 times the tube diameter.

If the tubing is ovalised during bending, the ratio of minor to major diameter must be 0.9 or greater.

The surface at the level of the bends must be smooth and even, without ripples or cracks.

### 3.5. Guidance on welding

These must be carried out along the whole perimeter of the tube. All welds must be of the highest possible quality with full penetration and preferably using a gas-shielded arc.

### 3.6. Protective padding

Where the occupants' bodies could come into contact with the safety cage, flame retardant padding must be provided for protection.